



## REX-1100 Mist Eliminator

### *For medium size machine tools!*

Suitable for medium to large machine tools up to 350 ft<sup>3</sup> enclosures. Ideal for high pressure coolant.

The innovative 1<sup>st</sup> stage mechanical elements separates up to 95% of the mist. The 2<sup>nd</sup> stage agglomerator is very unique, manufacture in layers of stainless steel wire mesh weaved with oil attracting fibers. Efficiency is high as the air travels though a bed of coarse and fine fibers at a low velocity. Channels between each layer provide exceptional fluid drainage. Optional is a Clean In Place (CIP) system for flushing out congealed coolant concentrate and fine solids. Alternatively, the media can be cleaned in placed with coolant or water hose. On most applications, cleaning is only every 2 years. The 2<sup>nd</sup> stage media is very durable, lasting up to 10 years.

The 3<sup>rd</sup> stage polishing filter or HEPA filter captures sub-micron mist, smoke and bacteria. Typical life is 1 – 3 years.



### Specifications:

Air flow	950 – 1150 cfm
Pressure (HEPA)	0 – 3.5" wg
Motor rating	3 hp
Voltage (amps)	230/460/3/60 (7.43 / 3.71) 600/3/60 (-----)
Speed	3450 rpm
Temperature (max)	160°F / 70°C
Weight	300 lbs / 96 kg
Height	50" / 1270 mm
Width	29.5" / 750 mm
Inlet connection	8"
Sound level	78 dB(A)
Clean air measurement	< 0.020 mg/m <sup>3</sup>

### Optional:

Clean In Place (CIP) System  
HEPA pre-filter  
Heavy duty 2<sup>nd</sup> stage agglomerator for fine mist applications.

### Accessories:

Suction hose  
Flange with hose nipple  
Chip strainer  
Mounting stand  
Wall rack  
Motor starter panel  
VFD motor starter  
VFD motor starter control panel  
VFD 2 speed motor starter control panel

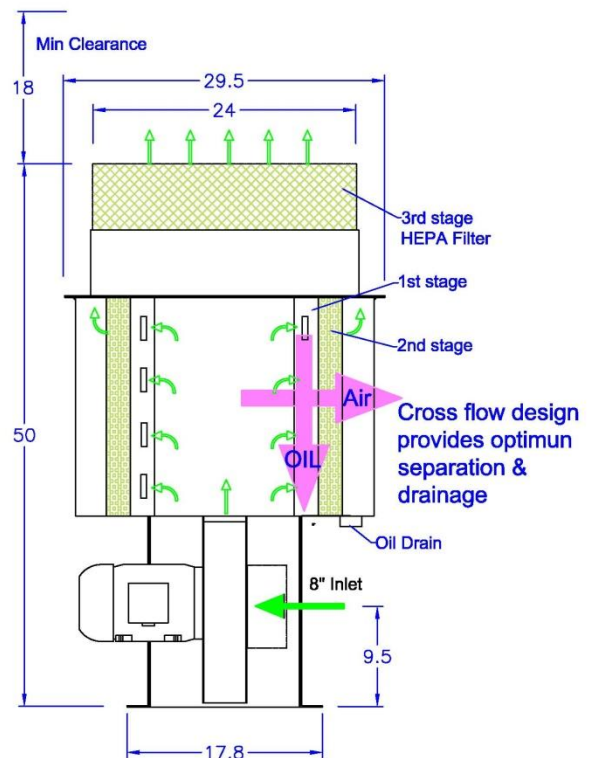

AEROEX International Inc.  
90 Ellis Dr.  
Barrie, ON, Canada, L4N 8Z3  
Tel: 705-734-0549 Fax: 705-734-1013

Sales  
Tel: 905-655-7295 Fax: 905-655-7293  
e:mail: [sales@aeroex.ca](mailto:sales@aeroex.ca)

[www.aeroex.ca](http://www.aeroex.ca)